



AVI ← **AIR**

 **Heat Exchanger**

Avi35



Automated washing system

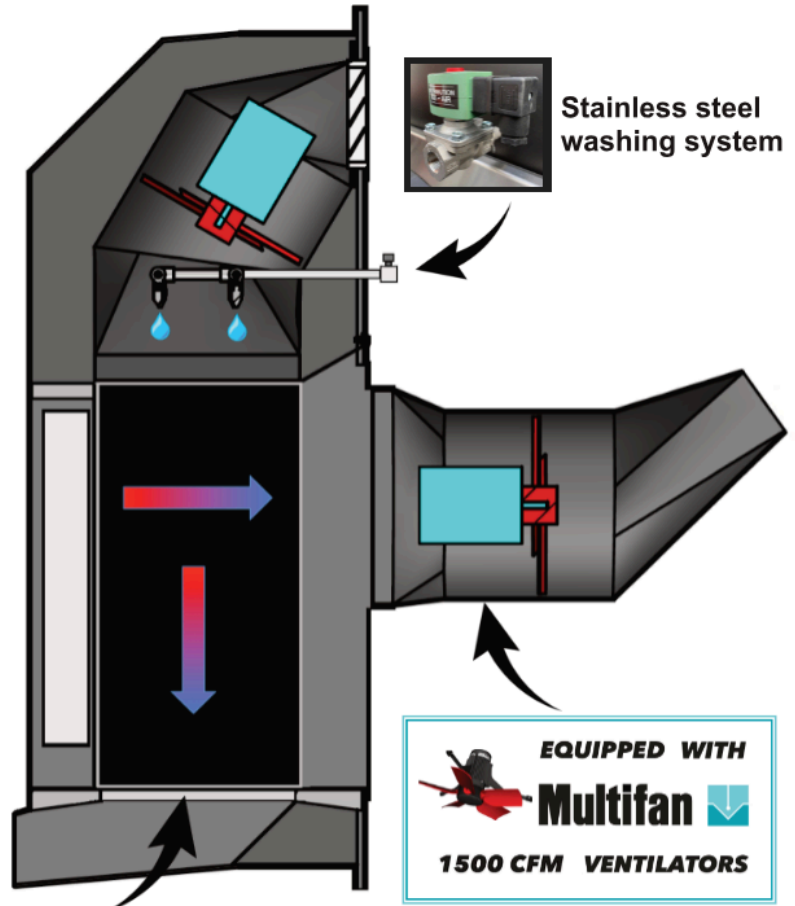
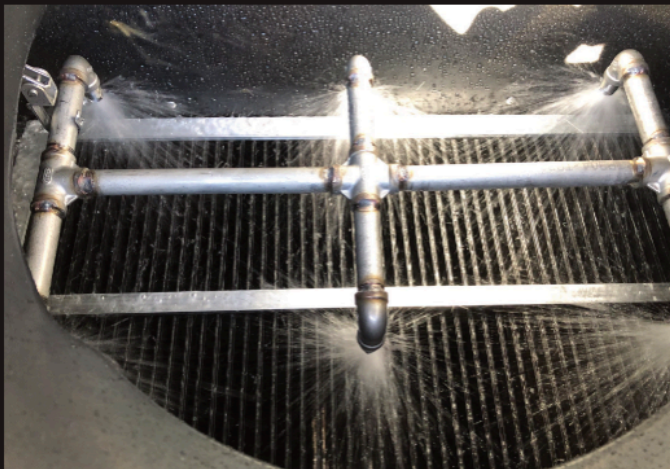

Easy cartridge maintenance



- Up to 50% fuel savings
- Lowers relative humidity
- CO₂ and ammonia reduction
- Improves litter and air quality

" Lower energy consumption is only half of the benefits. Better air quality, dryer litter, basically healthier and consistent environment is a real plus. "

Jean Ranger, St-Isidore, Ontario



Distributed By:

EXACON INC.



AVI ↔ AIR

Heat Exchanger

Avi35

Avi28 Controller



- Can manage up to 5 heat exchangers
- programmed washing cycles
- Intelligent defrost logic
- heating, water meter, timer relays
- 0-10 volt, humidity and temperature input signals



COMPATIBLE WITH:
FarmQuest
 LIVESTOCK MANAGEMENT
www.farmquest.com

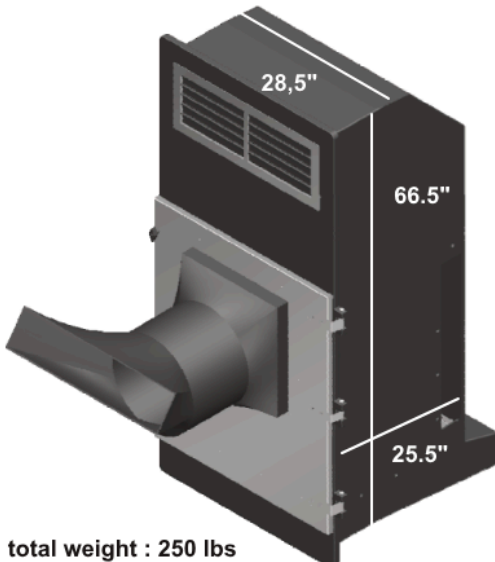

total weight : 250 lbs

Psychrometric output and efficiency of the Avi35

Min output 375 CFM
 Max output 1500 CFM
 Max sensible temperature recovery at 375 CFM 71%

Avi35 total heat flow in BTU/hr $1,88 \times \text{CFM} \times \Delta^\circ\text{C}$

Temperature at 0°C s and 0 static pressure

CFM output	375	525	750	1125	1500
Sensible temperature transfer efficiency	71%	66%	61%	57%	55%
Enthalpy transfer efficiency	41%	38%	35%	32%	30%
Total heat flow BTU/hr	14535	18118	21960	29770	37143

Total heat flow --- sensible + latent

AVI35 heat recovery in BTU / hr at 23 °C room temperature

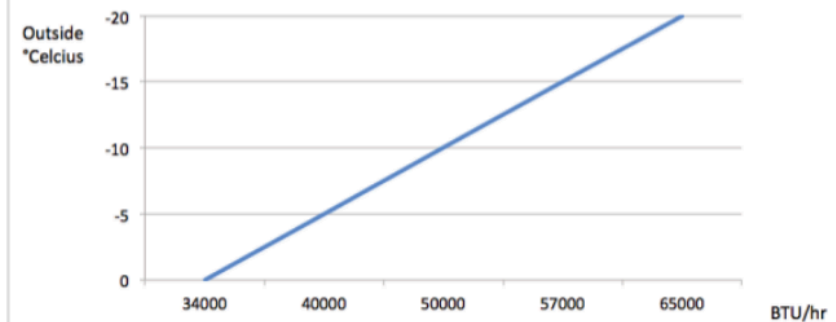

Electrical specifications of the Avi35



Intake ventilator specifications 240 Volts at 60 Hz , 1,9 amps
 Intake ventilator rotation max speed 3200 RPM

Exhaust ventilator specifications 240 Volts at 60 Hz , 1,9 amps
 Exhaust ventilator rotation max speed 3200 RPM

Water valve 240 Volts at 60 Hz , 17 watts

AVI35 Heat exchanger core

Heat exchange surface area 35 square meters
 Ventilation Type Cross flow
 Material polypropylene and aluminum





AVI ↔ AIR

Heat Exchanger

Avi35

Broiler barn gas economy analysis

CTGN Winter 2019 Natural Gas Economie				
	1st Cycle	2nd Cycle	3rd Cycle	Weekly Average
Week 1	NA	8%	19%	14%
Week 2	25%	27%	43%	32%
Week 3	57%	40%	50%	49%
Week 4	47%	61%	60%	56%
Week 5	70%	69%	NA	69%
Cycle Average	55%	41%	43%	48%

Échangeur-récupérateur pour poulailler Projet no : 421718

CTGN, Natural gas technology center, measured an average 48 % gas economy with broiler bar equipped with Avi35s.

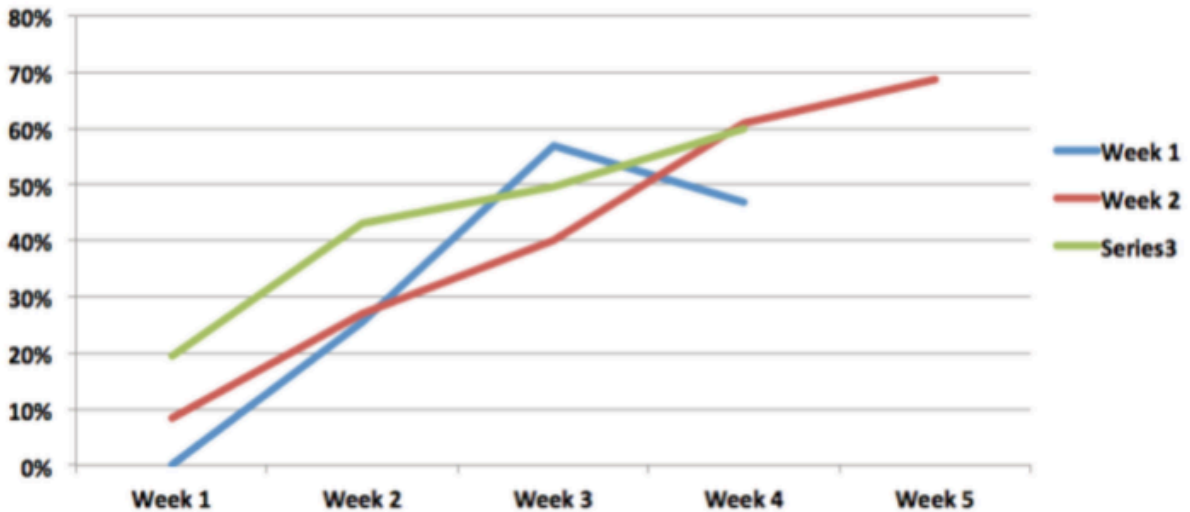

After week 2, most of the energy required to heat the barn comes from the heat exchanger as oppose to heaters. This is when gas economy is most significant.