

**AVI → AIR**  
 Heat Exchanger

# Avi35

REVISED: MAY 20, 2024

## Characteristics

- Recovery Mode air flow is 1500CFM
- Evacuation Mode air flow is 3200 CFM
- 35 square meters of heat exchange surface (377 sq.ft.)
- Up to five washing cycles
- Intelligent de-icing cycles
- Insulated polypropylene housing and door

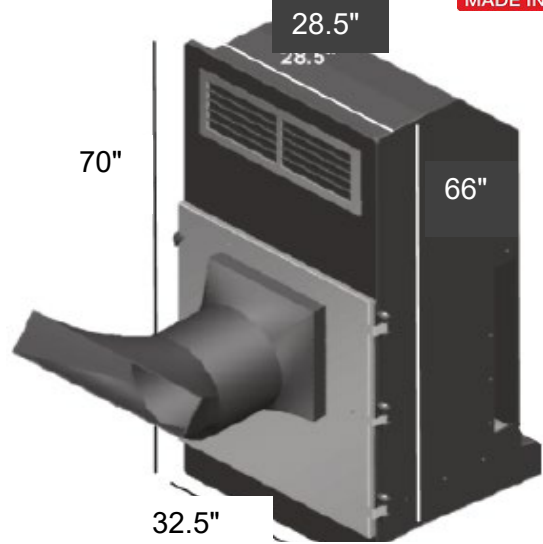

R.S.O. 29.00"W x 66.50"H

## AVI-28 Controller



- Can control up to 7 heat exchangers
- Daily washing cycles
- Intelligent de-icing cycles
- FarmQuest compatible

## Genius Compatible



The Avi-28 features are programmed into the larger Genius Itouch controller.



PART #	DESCRIPTION
E58-0135	Avi35 HYBRID HEAT RECOVERY UNIT
E58-0135EC	Avi35 with EC MOTORS <b>W/O 2WAY CONT.</b>
E58-0135MX	Avi35 HYBRID <b>W/O 2WAY CONTACTOR</b>
E58-0122	AVI-28 CONTROLLER <i>*CALL SALES FOR INFO</i>
E58-0121	Avi-35 SOLENOID VALVE
<b>OPTIONAL</b>	
E52-6561HD	Avi35 INTAKE INSULATED COVER (16"SQ.)
E52-6560HD	Avi35 EXHAUST INSULATED COVER

**CALL TO  
 CONFIRM  
 APPLICABLE  
 DISCOUNT**

**IF 2 WAY CONTACTOR (PART# E58-0120) IS NOT REQUIRED, USE PART # E58-0135MX**