

## STIR FANS

### FEATURES

- High ambient temperature of 140°F / 60°C
- Multiple mounting options
- Easy to install
- Sealed ball bearings with high temperature grease
- 3 year motor warranty



PART#	MODEL	DIA.	VOLT	AMPS	R.P.M.	CFM @ 0" S.P.
E54-4530W	SF30120	30"	120	6.7	1000	8950
E54-4630W	SF30240	30"	240	2.8	1000	8650

### OPTIONAL MOUNTING BRACKETS

PART #	MODEL #	DESCRIPTION
E54-5330	BRACKETW24/30	SMALL WALL BRACKET W/SWIVEL 15" OFFSET
E54-5332	BRACKETW30	LARGE WALL BRACKET W/SWIVEL 27.25" OFFSET

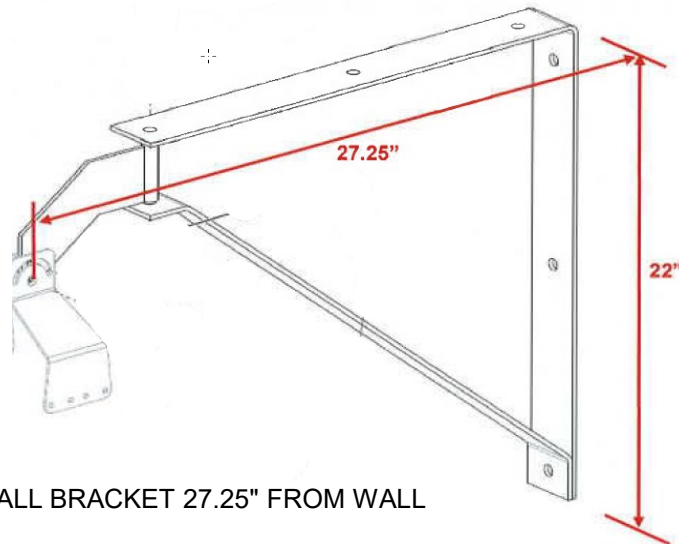

LARGE WALL BRACKET 27.25" FROM WALL